

INSTRUCTION MANUAL

TROUPERETTE III

Follow Spotlight

Type 45003-5,6

Rev. 7/99



STRONG INTERNATIONAL

a division of Ballantyne of Omaha, Inc.

4350 McKinley Street

Omaha, Nebraska 68112 USA

Tel 402/453-4444 • Fax 402/453-7238

FIGURE 1

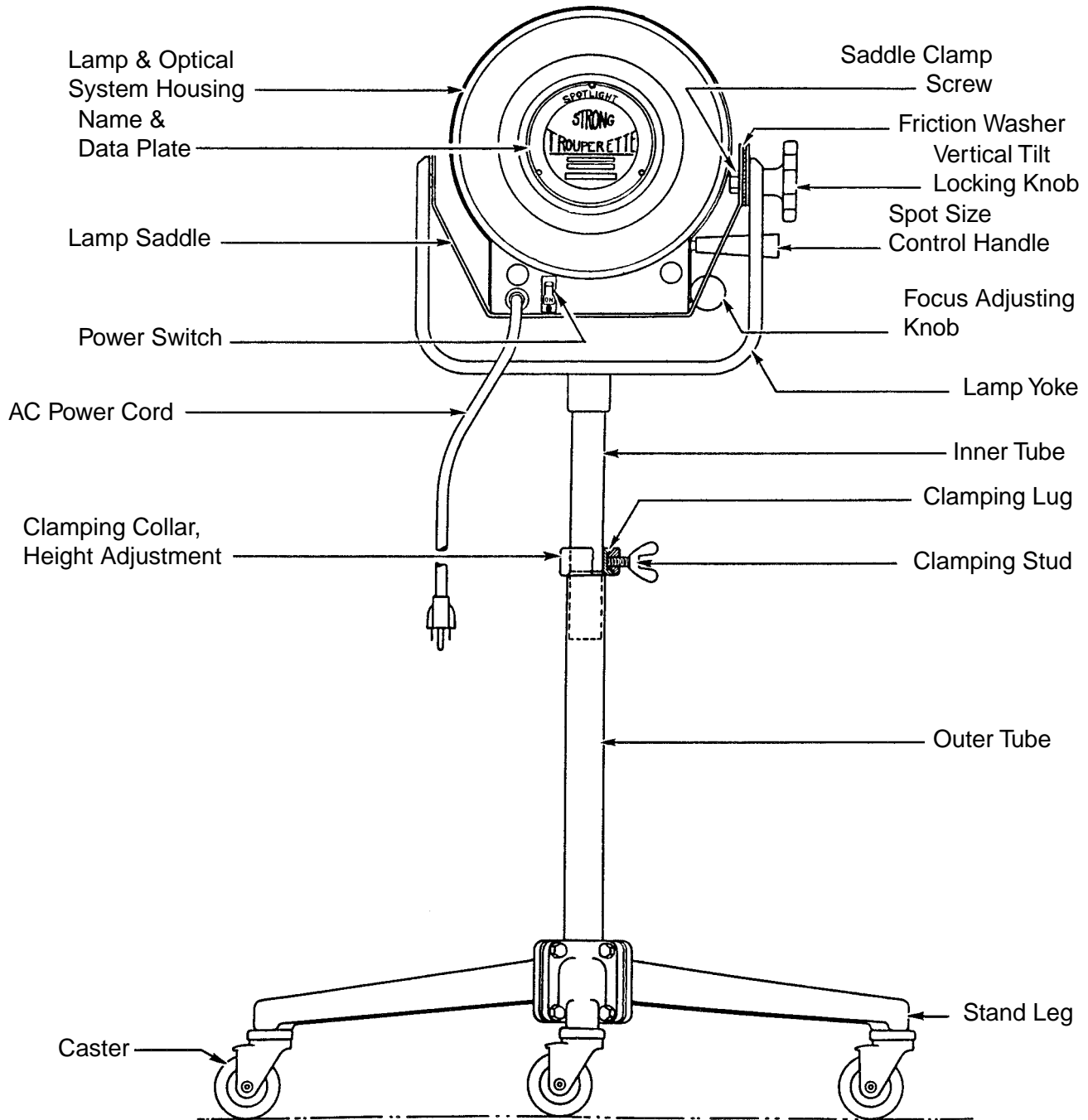

TROUPERETTE III

TROUPERETTE III Spotlight Set-Up

FASTEN THE THREE STAND LEGS (Figure 1) to the lower end of the outer tube using the (6) cap screws, lockwashers, and hexnuts furnished in the accessory box. Insert the casters into the holes provided in each leg only if the spotlight is to be portable. If the spotlight is to remain in a fixed location, do not insert the casters, but use the holes in the stand legs for hardware (not supplied) to bolt the stand to the floor.

TIGHTEN THE CLAMPING STUD to secure the height adjust collar. Mount the spotlight head to the lamp yoke by lowering the lamp saddle into the slots provided. Make certain the leather friction washer disc is between the flat metal friction surfaces of the saddle and yoke. Clamp the spotlight head in a horizontal position by tightening the cast vertical tilt locking knob onto the saddle clamp screw.

TO SET THE DESIRED THE HEIGHT OF THE SPOTLIGHT, loosen the clamping stud of the height adjustment clamp and raise or lower as desired. The height range from floor to optical center is 43 inches (1.1 m) to 60 (1.5 m) inches.

THE TROUPERETTE III requires a 1000 watt, 120 volt Type FEL projection bulb for domestic (USA) operation. An export model (45003-06) is available, and uses a 1000 watt, 240 volt Type FEP bulb. The rated life of either bulb is 250 hours, and it is advisable to have a spare bulb available (FEL - Part No. 45246; FEP - Part No. 45272).

TO INSTALL THE BULB, dismount the rear Name & Data Plate by removing the (3) socket head cap screws. See the Detail drawing on Figure 4. Loosen the two thumb screws (Item 11) enough to slide the support bracket and bulb socket (Items 13 & 14) through the rear opening and out of the lamphouse. *Do not alter the position of the stop plate (Item 5).* Grasp the bulb by its metal base and push it firmly into the center of the socket (Item 14). **CAUTION:** Avoid touching the bulb envelope; skin oils in fingerprints will etch the envelope and possibly shorten the expected bulb life. Remove any accidental fingerprints immediately using alcohol and a clean, soft cloth.

SLIDE THE ASSEMBLED BRACKET and bulb back onto the support (Figure 4, Item 12) up to and resting against the stop plate (Item 5). Tighten the two thumb screws (Item 11) to secure the bulb and bracket in position, and replace the rear cover plate.

CONNECT THE LEAD CORD PLUG to an AC receptacle of the correct voltage (see Equipment Data Plate; 45003-05 = 120 V.AC, 45003-06 = 240 V.AC). Turn the lamp ON by means of the power switch and inspect the projected spot. If the spot is not satisfactory, see the instructions following regarding Reflector & Bulb Adjustments.

WHEN MOVING THE SPOTLIGHT from one location to another, it is highly advisable to remove the bulb and pack it separately. The bulb filament is very fragile and susceptible to breakage from jars and shocks, particularly after prolonged operation.

OPERATION OF OPTICAL SYSTEM

THE SPOT SIZE CONTROL HANDLE (“trombone”) is located on the right-hand side of the spotlight housing just above the base pan. A variation of spot sizes in a ratio of 5:1 can be obtained with the movement of the Spot Size Control from one extreme to the other.

THE APERTURE SELECTOR (“iris”) is the front handle projecting through the top of the lamphouse cover plate casting. When this handle is to the left (viewing spotlight from the rear), the largest aperture is open. Smaller apertures are obtained as the handle is moved to the right.

THE SPOT FOCUSING CONTROL KNOB is located on the lower right side of the optical system base pan, toward the front of the unit. This control is used to adjust the optical system for the length of throw. A nominal (“average”) setting of this control can be made by positioning the aperture selector (iris) handle to the right, and sliding the spot size control (trombone) to the extreme front. Then rotate the knob until the sharpest white light is obtained on the projected spot. If the spotlight remains at a given throw point, the focus control can be set to best sharpen the edge of the projected spot.

MAXIMUM “FLOOD” SPOT is obtained by opening the aperture selector (iris) by moving its control handle to the left, and sliding the spot size control (trombone) to its extreme rear stop. If projecting a flood spot for a prolonged period, it may be desirable to adjust the focus control to sharpen the edge of the spot.

SMALLER SIZED SPOTS are projected as the spot size control (trombone) is moved forward. Most commonly used spot sizes (head-to-foot “body” spots) are produced with a large aperture (iris open) and a small spot (trombone forward).

FOR A “HEAD” SPOT, or any spot smaller than can be obtained with the spot size control (trombone) in the extreme forward position, shift the aperture selector handle toward the right to close the iris and project a smaller spot. The aperture selector handle should always be returned to its extreme left setting before the spot size control handle is again moved to project larger spots.

A “DIFFUSED” SPOT is projected by pulling the spot size control (trombone) back toward “flood” setting while closing the iris (aperture selector handle toward right). A “diffused” spot is seldom required, and is a “soft” edged spot with low light intensity.

THE MASKING SHUTTER AND DOUSER HANDLE (“chopper”) is the rear lever projecting through the top of the lamphouse cover casting. The masking shutter (chopper) blades are operated by this lever to shape the projected spot to a rectangle, a light strip, or to douse the spot for blackout. When the masking shutter control lever is to the extreme right, the chopper blades are open, and a round spot is projected. Varying degrees of top-and-bottom masking, to complete douse (light cutoff), are obtained as the lever is moved to the left.

ANGULAR ADJUSTMENT OF MASKING SHUTTER BLADES

THE ANGULARITY of the masking shutter (chopper) blades can be adjusted to compensate for the horizontal projection angle, for example, if the spotlight is positioned to the left or right of center stage. Remove the spotlight housing to expose the optical system.

AN UNBALANCED CONDITION will occur when the housing is removed, so the vertical tilt locking knob should be tightened. Slide the large lens forward by moving the trombone handle to the extreme forward position; remove the spot size control handle. Unscrew the knobs from the iris and chopper levers. Remove all screws securing the housing to the base pan, and lift the housing from the base pan.

SEE THE DETAIL DRAWING on Figure 5. Loosen, but do not remove, the screws (Item 16) securing each of the chopper blades (Items 14 & 18). Angle the lower blade so that it lies parallel with the footlights, and tighten the lower screw. Operate the masking shutter lever to close the chopper blades, and cause the upper blade to align to the lower blade. Secure the upper blade by tightening its mounting screw. Check the setting by lighting the bulb and projecting a narrow strip spot to the stage. Replace the housing and controls.

OPERATION OF THE COLOR BOOMERANG

THE COLOR BOOMERANG (Figure 6) is equipped with six 3-1/2" color filter discs containing the following colors, in sequence, from rear to front: (1) Amber, (2) Flesh Pink, (3) Medium Pink, (4) Light Magenta, (5) Special Lavender, and (6) Special Steel Blue. Additional colors are available from theatrical supply dealers; specify ROSCOLUX® (or equivalent) *high temperature* gels.

THE SIX COLOR DISC CONTROL LEVERS are mounted in the cover casting directly in front of the aperture selector (iris) lever. To insert a color disc into the light beam, move the desired disc lever to its extreme left position. To release a color, return the lever to the extreme right. Always operate the color levers to the limits of their travel.

TO DISMOUNT A COLOR DISC, unscrew the knobs on the iris and chopper levers and remove the two screws securing the top cover casting to the housing. Lifting the cover casting from the spotlight will remove the boomerang assembly. Each color disc is mounted to its control arm by two split rivets. See Figure 6 Parts List for replacement discs.

ONE AUXILIARY COLOR FRAME is provided for use when any special colors or other media are desired. A gelatin filter cut to 9¼" x 9½" will fit inside the frame, and the frame slips into the spring filter holder clip at the front of the lamphouse below the light opening. Additional auxiliary color frames may be ordered from your Strong International Dealer (order 51233 Frame and 51234 Retainer Plate).

HANDLING THE SPOTLIGHT

GENERALLY THE BEST POSITION FOR OPERATION is to stand near the center of the spotlight on the right-hand side. The angle of tilt and the size and location of the porthole may, however, alter the position for most convenient operation. One hand should be kept on the spot size control handle, as the spot can thus be directed and changed in size simultaneously. The other hand is used for operation of the optical system and boomerang control levers, and generally steadying the spotlight.

THE VERTICAL TILT LOCKING KNOB on the side of the lamp saddle can be tightened or loosened to provide the desired degree of friction to suit the individual operator. A brake screw on the outrider of the large lens carriage (Figure 3, Item 15) can also be set to provide more or less “drag” to the spot size control handle.

REPLACEMENT AND ADJUSTMENT OF REFLECTOR AND BULB

THE REFLECTOR has been carefully aligned at the factory for maximum light collection and transmission, and under normal circumstances, its position should not be changed. If it becomes necessary to replace the reflector, tighten the vertical tilt locking knob to immobilize the spotlight, unscrew the knobs from the iris and chopper control levers, remove the spot size control handle, and dismount the spotlight housing.

SEE THE DETAIL DRAWING on Figure 4. Dismount the reflector (Item 15) by removing *only* the reflector mounting screws (Item 2). *Do not remove plate mounting screws (Item 16) or otherwise alter the location of the mounting plate (Item 1).* Install the replacement reflector (45245) without disturbing the position of the mounting plate.

IF THE ORIGINAL or a replacement bulb fails to produce a suitable spot, it may be (a) the bulb is not properly seated in its socket, or (b) because of manufacturing tolerances, the position of the bulb filament differs slightly from the bulb used prior. Project a spot with the iris open and the spot size control handle about five inches back from the front of the lamphouse. Rotate the focus knob to obtain the sharpest possible spot.

IF A DARK AREA APPEARS at the top or bottom of the spot, slightly loosen the two screws (Figure 4, Item 8) and move the bracket (Item 12) up or down on its slots to obtain even illumination. When corrected, tighten the two bracket mounting screws.

IF THE CENTER OF THE SPOT appears darker or brighter than the edges, loosen the two thumb screws (Figure 4, Item 11) and move the bracket (Item 13) slightly to the rear of the lamp-house. If this does not balance the light, the stop plate (Item 5) must be moved a little toward the front of the bracket (Item 12). Loosen the screws (Item 6) just enough to move the stop plate (Item 5) in small increments until an even spot is projected. When a satisfactory spot is obtained, tighten all fasteners securely.

MAINTENANCE

TROUPERETTE LENSES SHOULD BE CLEANED with a liquid lens cleaner formulated for use with coated lenses, and lens tissue. These items are available from theatrical or motion picture supply dealers. A good grade of alcohol and facial tissue may be substituted. *Do not use abrasive cleansers of any kind.*

TO CLEAN THE SMALL LENS, remove the top cover casting and boomerang to access the rear lens carriage. The back surface of the large lens can also be cleaned through this opening when the spot size control handle is moved to its extreme rear position. Returning the trombone handle to its front position allows the front surface of the large lens to be cleaned through the front opening of the spotlight housing.

THE INTAKE GRILLE of the fan should be cleaned regularly to prevent dust build-up, which could restrict air flow. A reduction in forced-air cooling will greatly shorten the life of the FEL or FEP bulb; replace the fan if defective. The fan motor incorporates sealed bearings and requires no lubrication.

PARTS LISTS
Trouperette III
Type 45003

| | |
|----------|---------------------------|
| FIGURE 2 | Floor Stand & Yoke |
| FIGURE 3 | Base Pan & Lens Mechanism |
| FIGURE 4 | Bulb & Reflector Mount |
| FIGURE 5 | Optical System |
| FIGURE 6 | Color Boomerang |

Replacement Parts for Strong Trouperette III Follow Spotlights are available through authorized Strong International Dealers *only*. Order by Part Number and Description.

Goods returned to Strong International must be marked with a **Return Authorization** number issued by Strong to its Dealer prior to shipment. Return freight must be prepaid.

FIGURE 2

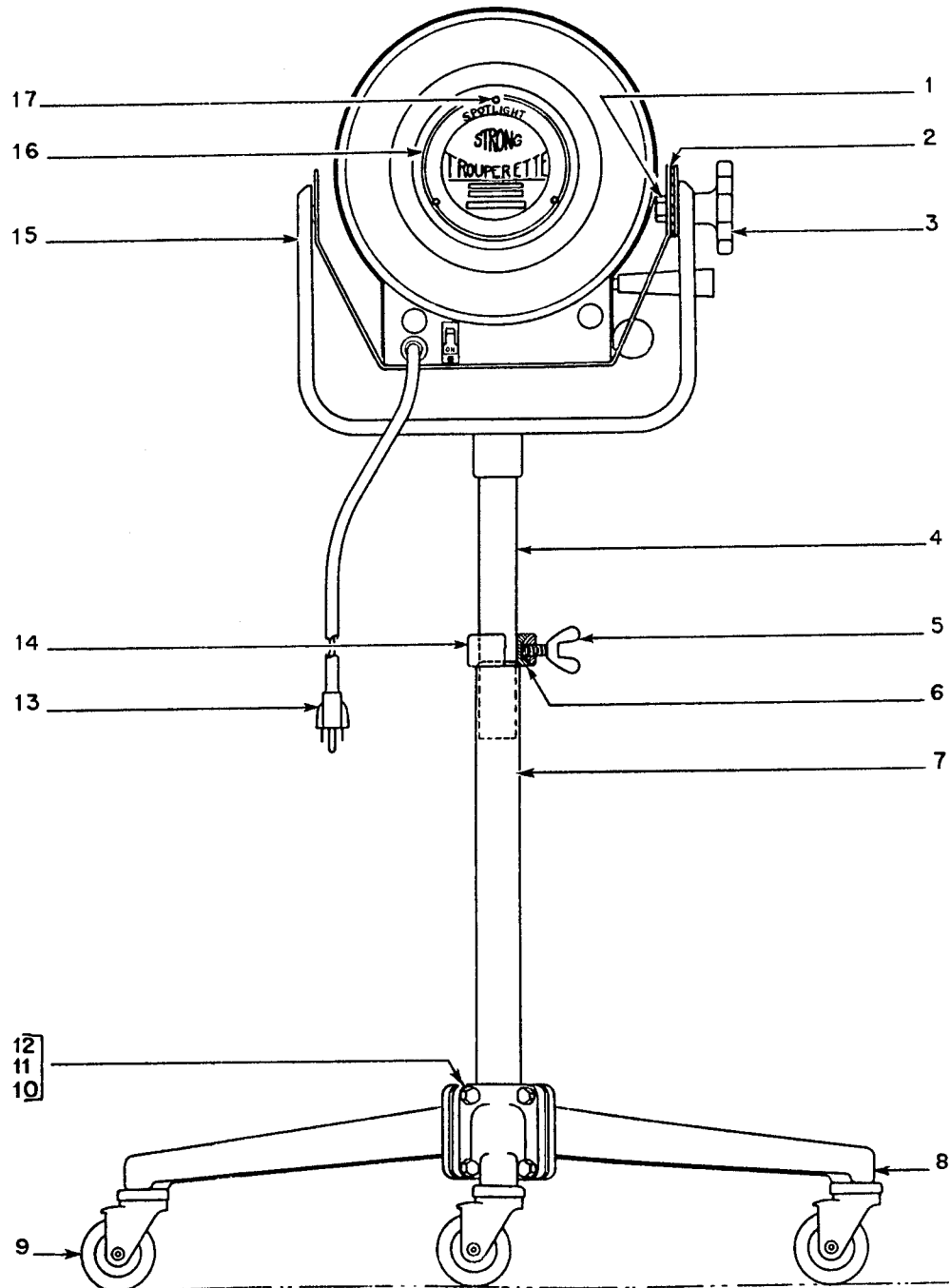

PARTS SHOWN ON ILLUSTRATIONS

| Figure | Item | Part No. | Description |
|--------|-------|---|--|
| 2 | 1 | 45152 | Screw, Saddle Clamp |
| | 2 | 45151 | Friction Washer, Leather |
| | 3 | 45153 | Vertical Tilt Locking Knob, Cast |
| | 4 | 45987 | Inner Tube & Yoke, Welded Assembly (incl. Item 15) |
| | 5 | 01339 | Thumb Screw, 3/8-16 x 3/4" |
| | 6 | 45160 | Clamping Lug |
| | 7 | 45157 | Outer Tube, Base Stand |
| | 8 | 45156 | Leg, Base Stand (3 req'd.) |
| | 9 | 34014 | Swivel Caster, Plastic (3 req'd.) |
| | 10 | 00883 | Split Lockwasher, 5/16" |
| | 11 | 00808 | Half Nut, 5/16-18 Hex (41-35018) |
| | 12 | 00617 | Cap Screw, 5/16-18 x 1-3/4" Hex Head |
| | 13 | 45918 | AC Power Cord with Molded Plug, 120 V.AC |
| | — | 49295 | Plug, 230 V.AC (Export) |
| | 14 | 45159 | Collar, Height Adjust Clamp |
| | 15 | 45987 | Inner Tube & Yoke, Welded Assembly (incl. Item 4) |
| | — | 45966 | Trouperette Base & Stand Assembly (Items 4 - 15) |
| 16 | 45280 | Name & Data Plate/Back Cover | |
| 17 | 01777 | Mounting Screw, 10-32 x 1/2" Socket Head (41-51208) | |
| — | 00831 | Flatwasher, #10 | |
| — | 01507 | Tinnerman Nut, #10 | |

| Figure | Item | Part No. | Description |
|--------|-------|-------------------------------------|-----------------------------------|
| 3 | 1 | 01304 | Screw, 8-32 x 5/16" Pan Head |
| | - | 00886 | Lockwasher, #8 Split Ring |
| | 2 | 51493 | Ring, Large Lens Carriage |
| | 3 | 51492 | Rubber Edge Mounting |
| | 4 | 45209 | "E" Ring, 3/16" |
| | 5 | 00831 | Flatwasher, #10 |
| | 6 | 51133 | Lens Focus Adjusting Block |
| | 7 | 45208 | Shaft, Focus Adjusting |
| | 8 | 51114 | Stop Collar, Slide Rod |
| | - | 41-51178 | Set Screw, 10-32 x 1/4" Cup Point |
| | 9 | 48103 | Knob, Focus Adjust |
| | 10 | 41-51028 | Screw, 6-32 x 1/4" Pan Head |
| | — | 00892 | Lockwasher, #6 Shakeproof |
| | 11 | 45224 | Stud, Lens Focus |
| | — | 00541 | Screw, 1/4-20 x 1/2" Pan Head |
| | 12 | 51992 | Focus Ribbon, Welded Assembly |
| | 13 | 51509 | Handle, Red Plastic |
| — | 51508 | Shaft, Spot Size Control (Trombone) | |
| — | 00809 | Hexnut, 3/8-16 | |

FIGURE 3

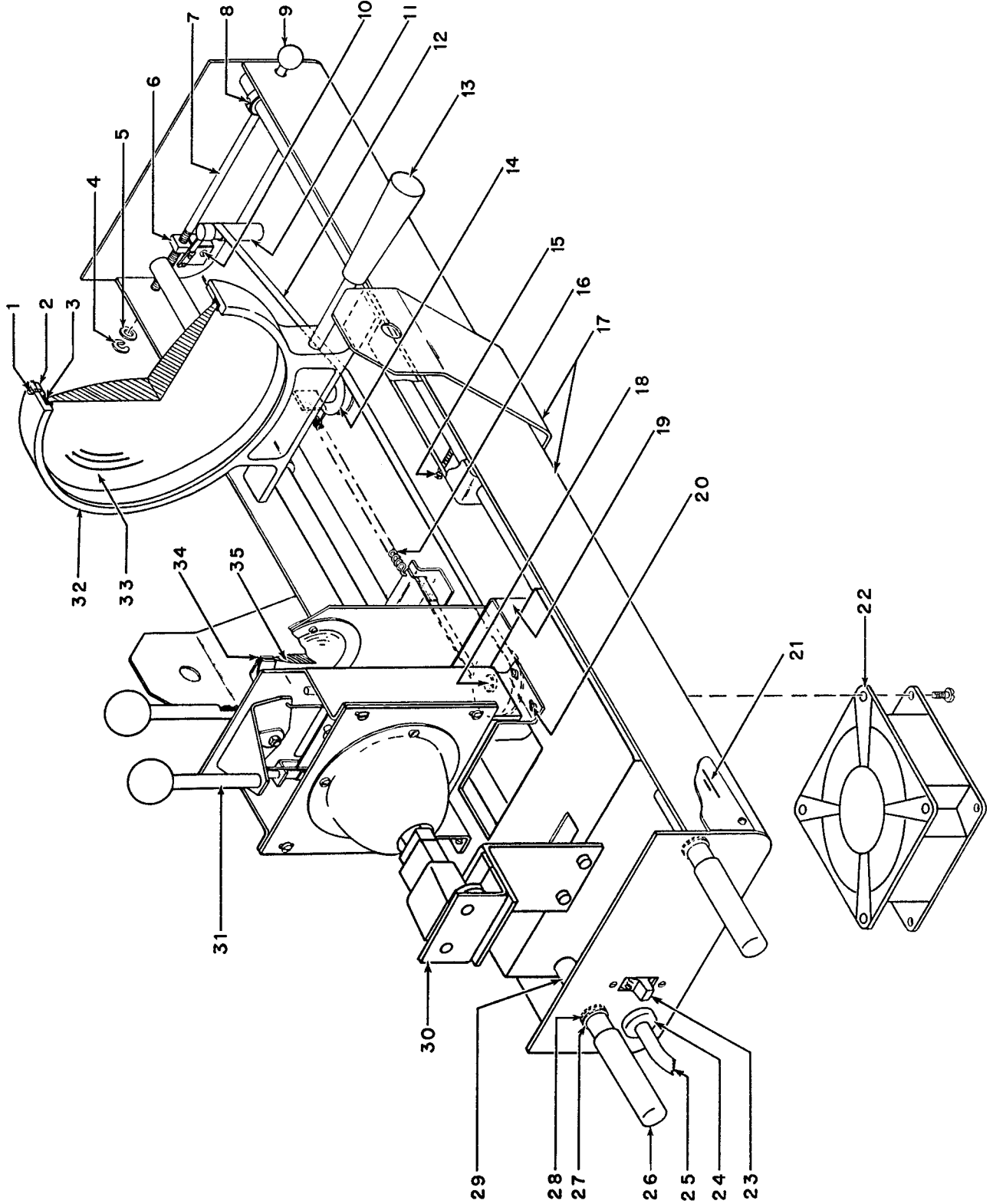

| Figure | Item | Part No. | Description |
|----------|------|----------|--|
| 3 | 14 | 51158 | Lens Ribbon Pulley, Small |
| (Con'd.) | — | 51160 | Pulley Stud |
| | 15 | 01752 | Screw, Lens Friction Brake; 1/4-20 x 1" Hex Head (Nylon) |
| | — | 01754 | Lock Nut, Friction Brake; 1/4-20 Hex (Nylon) |
| | 16 | 51162 | Expansion Spring, Lens Ribbon |
| | 17 | 45945 | Base Pan & Saddle, Welded Assembly |
| | 18 | 51157 | Lens Ribbon Pulley, Large |
| | — | 51160 | Pulley Stud |
| | — | 00830 | Spacer Washer, #8 Flat |
| | 19 | 45930 | Small Lens Carriage, Welded Assembly |
| | 20 | 01777 | Screw, 10-32 x 1/2" Socket Head (41-51208) |
| | — | 45258 | Shim (below Aperture Support) |
| | 21 | 45942 | Spotlight Housing, Welded Assembly |
| | — | SC-0536 | Mounting Screw, 10-32 x 1/4" Binding Head |
| | 22 | 61-98002 | Fan, 4" Square Frame, 120 V.AC, 50/60 Hz. |
| | — | 81272 | Fan, 4" Square Frame, 240 V.AC, 50/60 Hz. (Export) |
| | — | 45225 | Cord & Plug, Fan |
| | — | 83131 | Inlet Grille, Plastic (Fan Guard) |
| | — | 00192 | Fan Mounting Screw, 6-32 x 2" Fillister Head |
| | — | 00892 | Lockwasher, #6 Shakeproof |
| | 23 | 45331 | Switch, Power ON - OFF, 120 V.AC (Domestic) |
| | — | 45281 | Switch, Power ON - OFF, 240 V.AC (Export) |
| | 24 | 23163 | Strain Relief Bushing |
| | 25 | 45918 | AC Power Cord with Molded Plug, 120 V.AC |
| | — | 49295 | Plug, 230 V.AC (Export) |
| | 26 | 45150A | Handle Grip, Plastic |
| | 27 | 91219 | "E" Ring, 5/8" Flat |
| | 28 | 46137 | "E" Ring, 5/8" Bowed |
| | 29 | 45278 | Slide Rod (Left & Right) |
| | 30 | - | See Figure 4 |
| | 31 | - | See Figure 5 |
| | 32 | 51856 | Large Lens Carriage Casting |
| | 33 | 51102 | Large Lens, 7" Diameter |
| | 34 | 45254 | Lens Retaining Ring |
| | — | 00179 | Screw, 6-32 x 1/4" Fillister Head |
| | — | 41-35005 | Hexnut, 6-32 |
| | — | 00892 | Lockwasher, #6 Shakeproof |
| | 35 | 45252 | Small Lens, 2.5" Diameter |

| Figure | Item | Part No. | Description |
|--------|------|----------|---|
| 4 | 1 | 45250 | Mounting Plate, Reflector |
| | 2 | 01748 | Sheet Metal Screw, 6-32 x 3/8" Hex Head |
| | 3 | 45246 | Tungsten-Halogen Bulb, 1000 Watt, Type FEL (Domestic) |
| | - | 45272 | Tungsten-Halogen Bulb, 1000 Watt, Type FEP (Export) |
| | 4 | 01311 | Screw, 8-32 x 3/8" Pan Head |
| | 5 | 45261 | Stop Plate, Bulb Bracket |

FIGURE 4

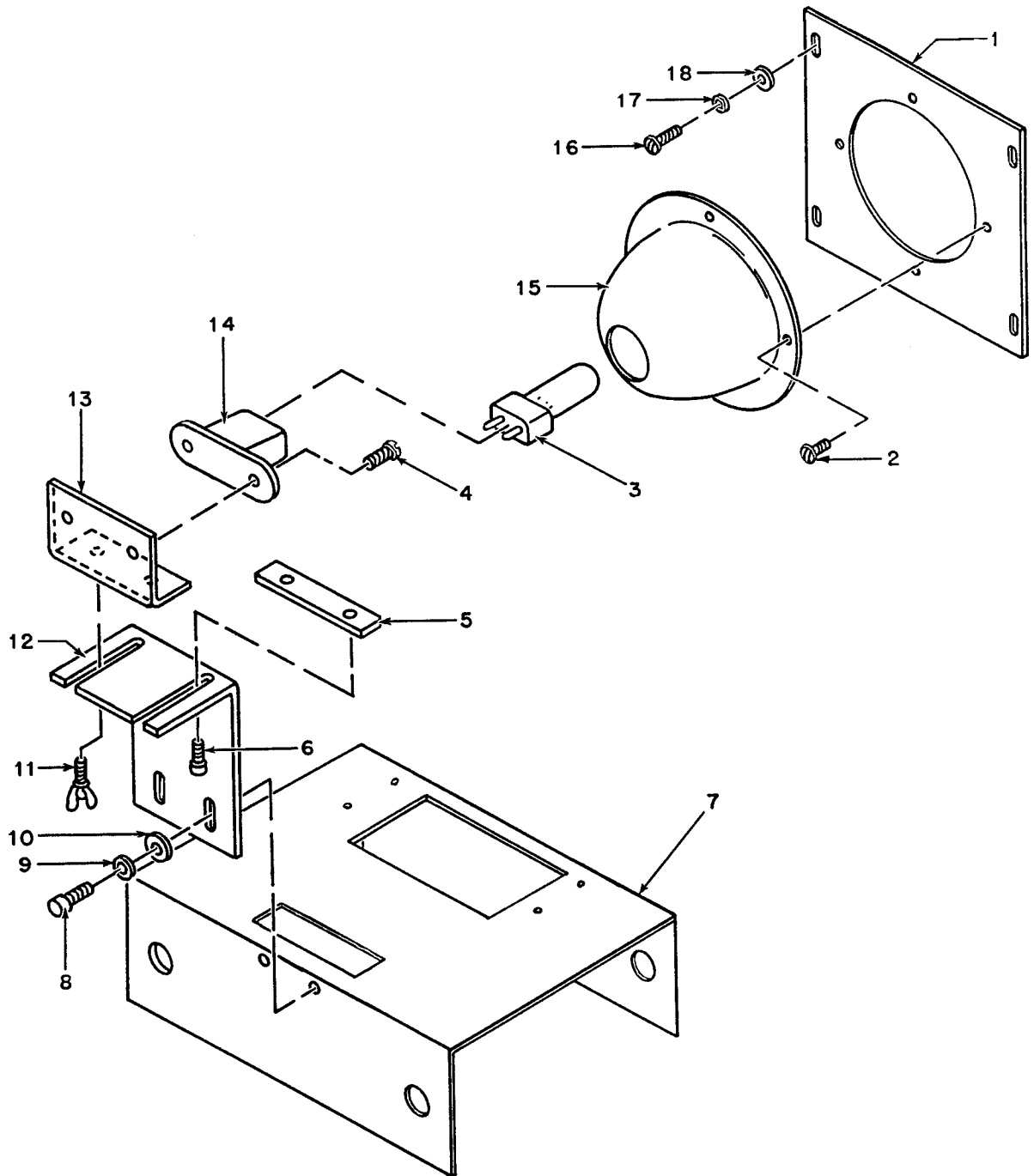
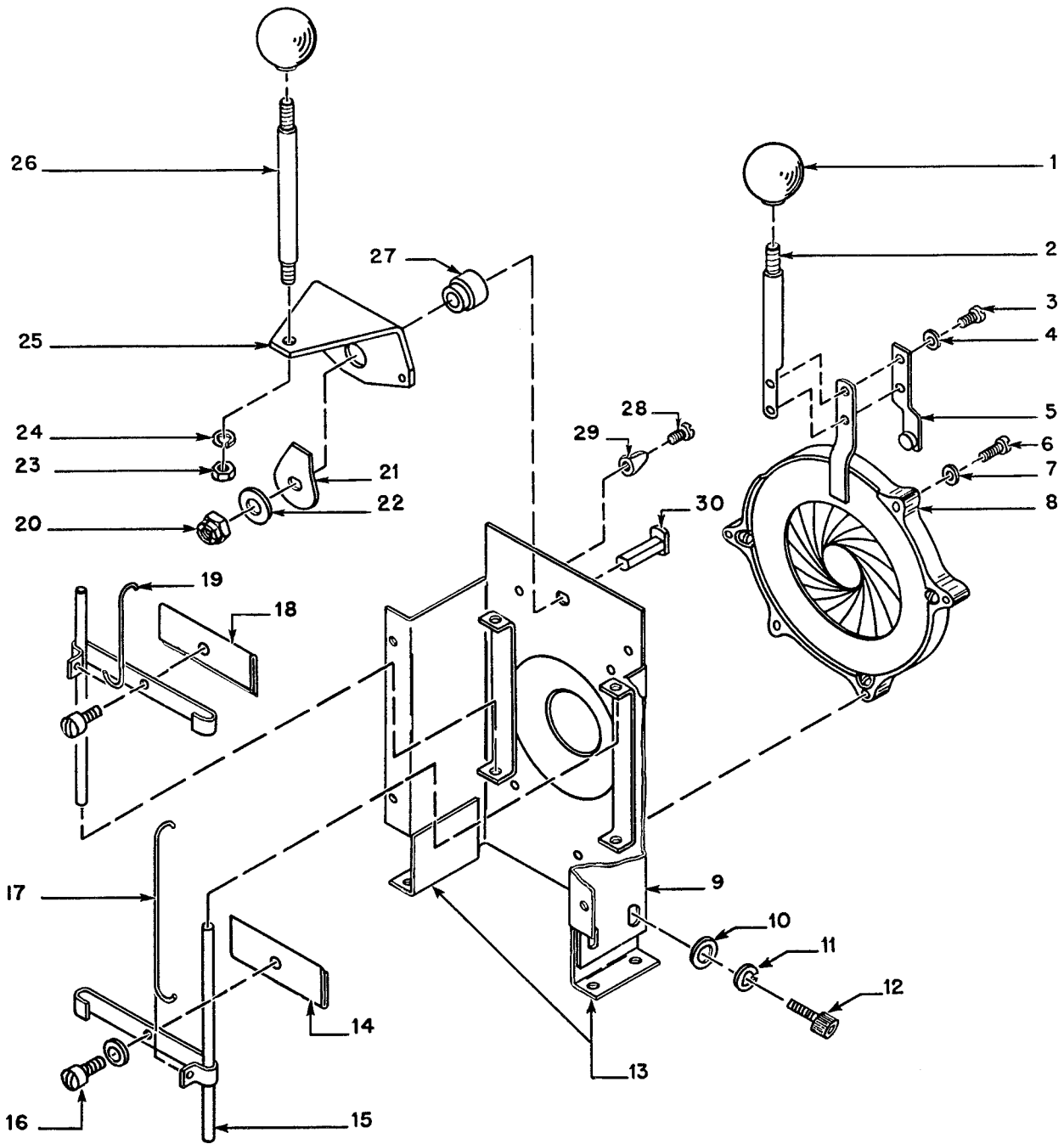

FIGURE 5



| Figure | Item | Part No. | Description |
|----------|------|----------|---------------------------------|
| 4 | 6 | 01744 | Screw, 10-24 x 1/2" Socket Head |
| (Con'd.) | - | 00831 | Flatwasher, #10 |
| | - | 01344 | Lockwasher, #10 Shakeproof |
| | 7 | 45275 | Lamphouse Support Bracket |
| | 8 | 01777 | Screw, 10-32 x 1/2" Socket Head |
| | 9 | 01344 | Lockwasher, #10 Shakeproof |
| | 10 | 00831 | Flatwasher, #10 |
| | 11 | 01695 | Thumb Screw, 10-24 x 3/8" |
| | 12 | 45263 | Support Bracket, Slotted |
| | 13 | 45262 | Bracket, Bulb Socket |
| | 14 | 45247 | Socket, 120/240 Volt, FEL/FEP |
| | 15 | 45245 | Reflector |
| | 16 | 01311 | Screw, 8-32 x 3/8" Pan Head |
| | 17 | 00886 | Lockwasher, #8 Split Ring |
| | 18 | 41-70002 | Flatwasher, #8 |

| Figure | Item | Part No. | Description |
|--------|------|----------|---|
| 5 | 1 | 10048A | Knob, Red Plastic |
| | 2 | 51228 | Shaft, Iris Control |
| | 3 | 00179 | Screw, 6-32 x 1/4" Fillister Head |
| | 4 | 00892 | Lockwasher, #6 Shakeproof |
| | 5 | 51978 | Friction Spring, Iris |
| | - | 51229 | Friction Pad |
| | 6 | 00183 | Screw, 6-32 x 1/2" Fillister Head |
| | 7 | 00892 | Lockwasher, #6 Shakeproof |
| | 8 | 51979 | Iris Assembly |
| | 9 | 45925 | Aperture Support Bracket, Welded Assembly |
| | 10 | 00831 | Flatwasher, #10 |
| | 11 | 01344 | Lockwasher, #10 Split Ring |
| | 12 | 01777 | Screw, 10-32 x 1/2" Socket Head |
| | 13 | 45924 | Mounting Bracket, Aperture Support (Left & Right) |
| | 14 | 47978 | Chopper Blade, Lower |
| | 15 | 47982 | Slide Assembly (Upper & Lower) |
| | — | 47972 | Lower Blade & Slide Assembly (Items 14 & 15) |
| | 16 | P-1732 | Screw, 8-32 x 3/16" Fillister Head (41-51318) |
| | — | 00886 | Lockwasher, #8 Split Ring |
| | 17 | 51497 | Pull Rod, Long |
| | 18 | 47979 | Chopper Blade, Upper |
| | — | 47973 | Upper Blade & Slide Assembly |
| | 19 | 51498 | Pull Rod, Short |
| | 20 | 01406 | Nut, 5/16-18 FlexLock |
| | 21 | 51156 | Friction Plate |
| | 22 | 00853 | Flatwasher, 5/16" |
| | 23 | 00805 | Hexnut, 1/4-20 |
| | 24 | 00876 | Lockwasher, 1/4" Split Ring |
| | 25 | 51488 | Bracket, Masking Control |

FIGURE 6

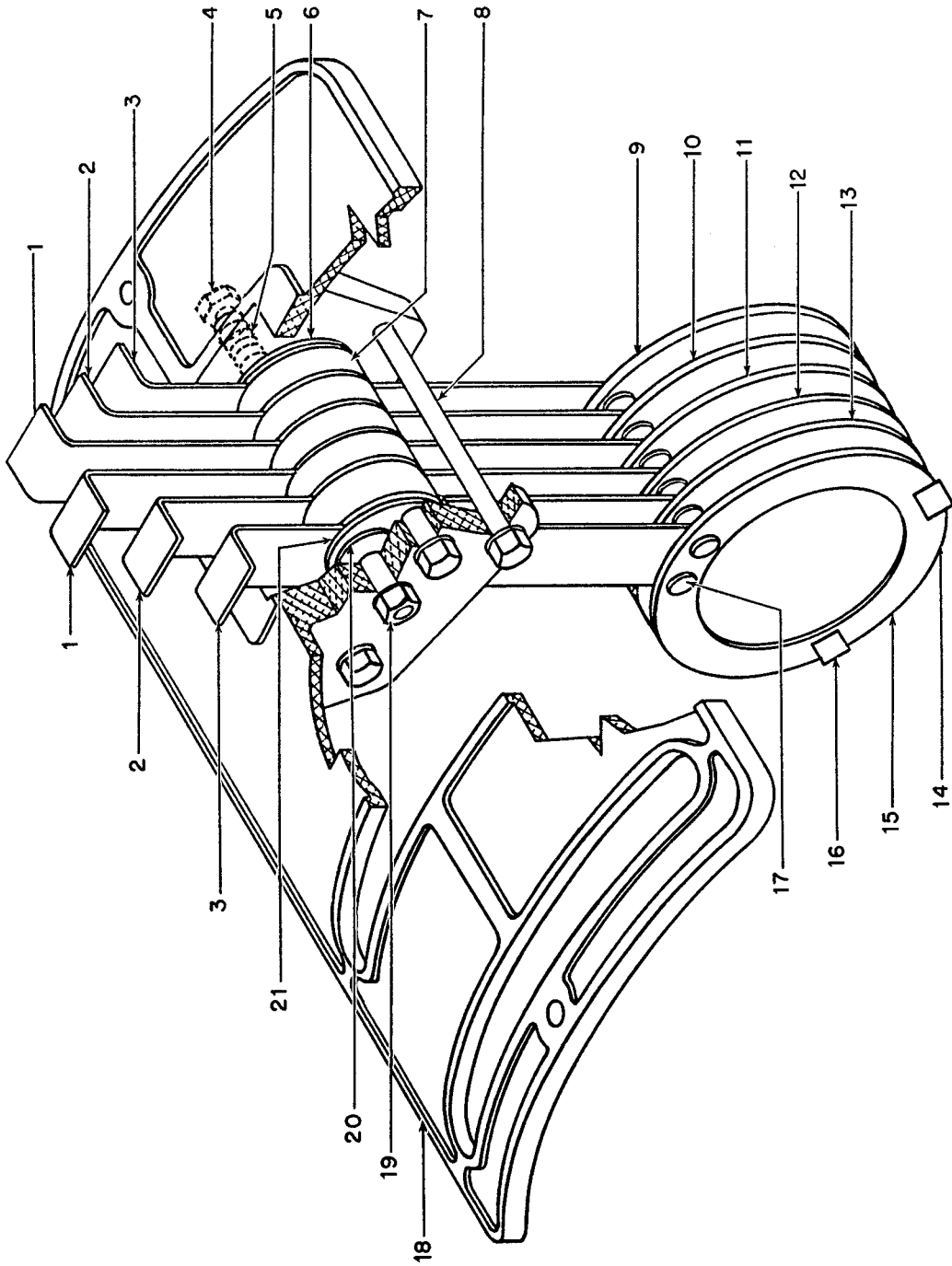

| Figure | Item | Part No. | Description |
|---------------|-------|---|-----------------------------------|
| 5 (Con'd.) | 26 | 51155 | Operating Shaft, Masking Control |
| | 27 | 51153 | Spacer Bushing |
| | 28 | 00254 | Screw, 8-32 x 1/4" Fillister Head |
| | 29 | 47170 | Iris Stop |
| | 30 | 51226 | Stud, Masking Control Bracket |
| — | 45916 | Aperture & Iris Assembly (Figure 5, Items 1 - 30) | |

| Figure | Item | Part No. | Description | |
|--------|-------|---|--|--|
| 6 | 1 | 45131 | Color Disc Handle, Long | |
| | 2 | 45130 | Color Disc Handle, Intermediate | |
| | 3 | 45129 | Color Disc Handle, Short | |
| | 4 | 00709 | Pivot Bolt, 1/4-20 x 4" Hex Head | |
| | 5 | 01026 | Compression Spring | |
| | - | 45135 | Pivot Bolt Bushing | |
| | 6 | 45133 | Spacer, Nylon (Thin) | |
| | 7 | 45134 | Spacer, Nylon | |
| | 8 | 01743 | Stop Bolt, 1/4-20 x 3-1/2" Hex Head | |
| | 9 | 45981 | Color Disc Assembly, Special Steel Blue | |
| | 10 | 45982 | Color Disc Assembly, Special Lavender | |
| | 11 | 45983 | Color Disc Assembly, Light Magenta | |
| | 12 | 45984 | Color Disc Assembly, Medium Pink | |
| | 13 | 45985 | Color Disc Assembly, Flesh Pink | |
| | 14 | 45986 | Color Disc Assembly, Amber | |
| | — | 41944 | Color Disc Assemblies, Set of Six (Items 9 - 14) | |
| | 15 | 45122 | Color Frame, 3-1/2" | |
| | 16 | 46150 | Clip, Color Frame | |
| | 17 | 01456 | Split Rivet | |
| | 18 | 45132 | Cover Plate Casting | |
| | 19 | 01754 | Hexnut, 1/4-20 Nylon | |
| 20 | 00852 | Flatwasher, 1/4" S.A.E. | | |
| 21 | 45133 | Spacer, Nylon (Thin) | | |
| — | 45991 | Color Boomerang Assembly (Figure 6, Items 1 - 21) | | |

Theatrical Supply Dealers generally stock a complete selection of color media, including color correction filters (required for television & videotaping). Specify ROSCOLUX® or equivalent **high temperature** gels.

Install darker gels (red, green, dark blue) toward the *front* of the boomerang (**away** from the bulb) and gels of lower density (lighter colors) at the *rear* positions.

